

Technical Specifications

Design	ASME B16.34
Face to Face	EN 5558 Series 1, DIN 3202 F1
Size Range	DN15-DN100
Pressure Rate	Max.WP [Bar] (Ref. Table)
Ends Connection	RF DIN Flanges, EN 1092
Temperature Range	-20°C ~ 180°C
Application	Water, Oil & Gas

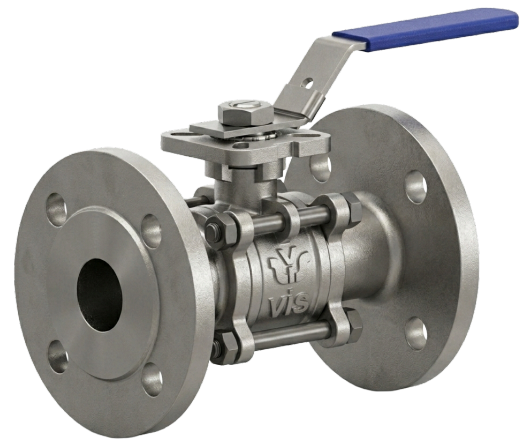

Component List

NO	PART NAME	MATERIAL
1	Body	CF8
2	Seat	PTFE
3	Ball	SS 304
4	Flange	CF8
5	Thrust Gasket	PTFE
6	Stem	SS 304
7	Stud	SS 304
8	Nut	SS 304
9	Packing	PTFE
10	Gland Nut	SS 304
11	Nut	SS 304
12	Handle	SS 201 + PVC
13	Lock	SS 201

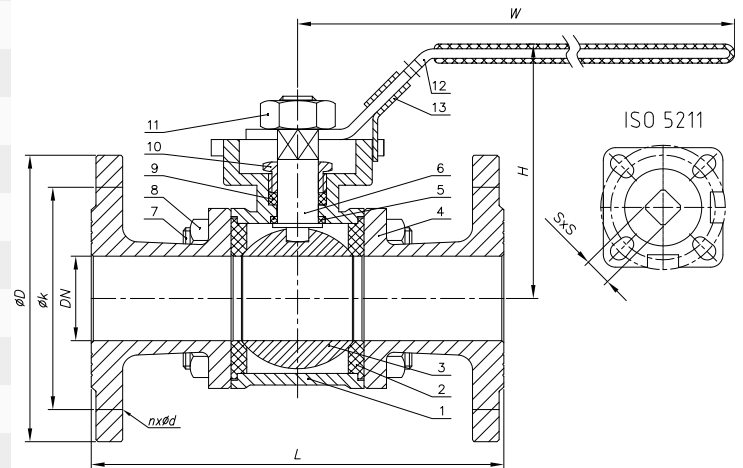

Dimensions

	DN	15	20	25	32	40	50	65	80	100
	Max.WP	40	40	40	40	40	40	40	40	40
	L	130	150	160	180	200	230	290	310	350
	H	63	74	86	95	116	122	147	153	167
	W	130	130	170	170	195	195	245	275	295
	ISO 5211	F03/F04	F03/F04	F04/F05	F04/F05	F05/F07	F05/F07	F07/F10	F07/F10	F07/F10
	SxS	9	9	11	11	14	14	17	17	17
PN 16	N.m	5	6	8	15	20	25	40	60	120
PN 40	N.m	8	8	10	20	25	35	50	90	175
PN 10	ØD	95	105	115	140	150	165	185	200	220
PN 10	Øk	65	75	85	100	110	125	145	160	180
PN 10	n x Ød	4x14	4x14	4x14	4x18	4x18	4x18	4x18	8x18	8x18
PN 16	ØD	95	105	115	140	150	165	185	200	220
PN 16	Øk	65	75	85	100	110	125	145	160	180
PN 16	n x Ød	4x14	4x14	4x14	4x18	4x18	4x18	4x18	8x18	8x18
PN 25	ØD	95	105	115	140	150	165	185	200	235
PN 25	Øk	65	75	85	100	110	125	145	160	190
PN 25	n x Ød	4x14	4x14	4x14	4x18	4x18	4x18	8x18	8x18	8x22
PN 40	ØD	95	105	115	140	150	165	185	200	235
PN 40	Øk	65	75	85	100	110	125	145	160	190
PN 40	n x Ød	4x14	4x14	4x14	4x18	4x18	4x18	8x18	8x18	8x22
	Kg	2.07	2.81	3.61	5.23	6.46	8.22	11.8	15.5	22.47

Designs, materials and specifications shown are subject to change without notice. VIS VANA reserves the right to modify information.